



EVERLIGHT ELECTRONICS CO.,LTD.

DATA SHEET

PART NO. : 19-217/Y5C-AP1Q2/3T

DATE :

DEPARTMENT : R.D.1

REVISION : 1.0

RECEIVED			
<input checked="" type="checkbox"/> MASS PRODUCTION			
<input type="checkbox"/> PRELIMINARY			
<input type="checkbox"/> CUSTOMER DESIGN			
DEVICE NUMBER : DSE-197-Y01			
PAGE : 11			
CUSTOMER	DESIGNER	CHECKER	APPROVER
	JESSICA CHANG	JEFF TSAI	CHARLES CHANG

REV	DESCRIPTION	RELEASE DATE

Package Type:

SMD For PCB Type

11-21	19-215
12-21	19-215A
12-215	19-217A
15-21	22-21
15-215	23-21
16-213	23-21B
17-21	24-21
17-215	25-21
19-21	27-21
19-21A	42-21

Dominant Wavelength Groups:

According to the difference wavelength to define
 None: No definition
 A : Standard wavelength definition.
 B : Range of wavelength definition is more narrowly than group A.
 C : Range of wavelength definition is more narrowly than group A, but the value is different with group B.
 F : The wavelength definition in special specification.

The dominant wavelength data did not including ±1nm testing tolerance.

Test Forward Current:

None: 20 mA
 Y : 5 mA
 Z : 10 mA

Taping Quantity:

- 1: 1000 pcs (Taping)
- 2: 2000 pcs (Taping)
- 3: 3000 pcs (Taping)
- 5: 5000 pcs (Taping)
- C : 1500 pcs (Taping)
- D : 10000 pcs (Taping)

Packing Method :

- A: Reverse-side placement (Anode toward the sprocket hole)
- B: Reverse-side placement (Anode toward the sprocket hole)
- C: Right-side placement
- D: Right-side placement (Anode toward the sprocket hole)
- T: Top-side placement
- R: Top-side placement (Anode toward the sprocket hole)

19 - 21 / B H C - A N1 P2 M / 3 T

Emission Color:

- R: Red (λ d: 640nm, 630nm, 625nm)
- S: Sunset Orange (λ d: 615nm, 605nm)
- Y: Yellow (λ d: 595nm, 590nm)
- G: Green (λ d: 570nm, 565nm, 560nm, 525nm, 505nm)
- B: Blue (λ d: 470nm)
- W: White x=0.32 y=0.31

The ordinal number that base on diffece electro-optical characteristics within chip.

1,2 7,8,9, A,B.....X,Y,Z

Resin Color:

- C: Water Clear
- W: White Diffused
- D: Diffused

Luminous Intensity Groups:

- | | |
|-------------------|---------------------|
| C0: 0.28 ... 0.45 | R ⇨ R1: 112 ... 140 |
| D0: 0.45 ... 0.70 | R2: 140 ... 180 |
| E0: 0.70 ... 1.1 | S1: 180 ... 225 |
| F0: 1.1 ... 1.8 | S2: 225 ... 285 |
| G0: 1.8 ... 2.8 | T1: 285 ... 360 |
| H0: 2.8 ... 4.5 | T2: 360 ... 450 |
| J0: 4.5 ... 7.2 | U1: 450 ... 565 |
| K0: 7.2 ... 11.5 | U2: 565 ... 715 |
| L1: 11.5 ... 14.5 | V1: 715 ... 900 |
| L2: 14.5 ... 18.0 | V2: 900 ... 1120 |
| M1: 18.0 ... 22.5 | W1: 1120 ... 1420 |
| M2: 22.5 ... 28.5 | W2: 1420 ... 1800 |
| N1: 28.5 ... 36.0 | X1: 1800 ... 2250 |
| N2: 36.0 ... 45.0 | X2: 2250 ... 2850 |
| P1: 45.0 ... 57.0 | Y1: 2850 ... 3600 |
| P2: 57.0 ... 72.0 | Y2: 3600 ... 4500 |
| Q1: 72.0 ... 90.0 | |
| Q2: 90.0 ... 112 | |

Unit: mcd

The luminous intensity data did not including ±15% testing tolerance.

Forward Voltage Groups:

None: No definition

The VF definition as follows:

		Unit: V			
Forward Voltage Group	Bin	Min.	Max.		
C	B	A	00	1.55	1.75
			0	1.75	1.95
			1	1.95	2.15
			2	2.15	2.35
			3	2.35	2.55
M	E	D	4	2.55	2.75
			5	2.75	3.05
			6	3.05	3.35
			7	3.35	3.65
			8	3.65	3.95
N	F	K	9	2.50	2.70
			10	2.70	2.90
			11	2.90	3.10
			12	3.10	3.30
			13	3.30	3.50
P	H	J	14	3.50	3.70
			15	2.70	2.85
			16	2.85	3.00
			17	3.00	3.15
			18	3.15	3.30

The forward voltage data did not including ±0.1V testing tolerance.



Technical Data Sheet

0.4mm Height Flat Top LED

19-217/Y5C Series

Features

- Package in 8mm tape on 7" diameter reel.
- Compatible with automatic placement equipment.
- Compatible with infrared and vapor phase reflow solder process.
- Mono-color type.

Descriptions

- The 19-217 SMD Taping is much smaller than lead frame type components, thus enable smaller board size, higher packing density, reduced storage space and finally smaller equipment to be obtained.
- Besides, lightweight makes them ideal for miniature applications. etc.

Applications

- Automotive: backlighting in dashboard and switch.
- Telecommunication: indicator and backlighting in telephone and fax.
- Flat backlight for LCD, switch and symbol.
- General use.

Device Selection Guide

Part No.	Chip		Lens Color
	Material	Emitted Color	
19-217/Y5C	AlGaInP	Brilliant Yellow	Water Clear

Package Outline Dimensions

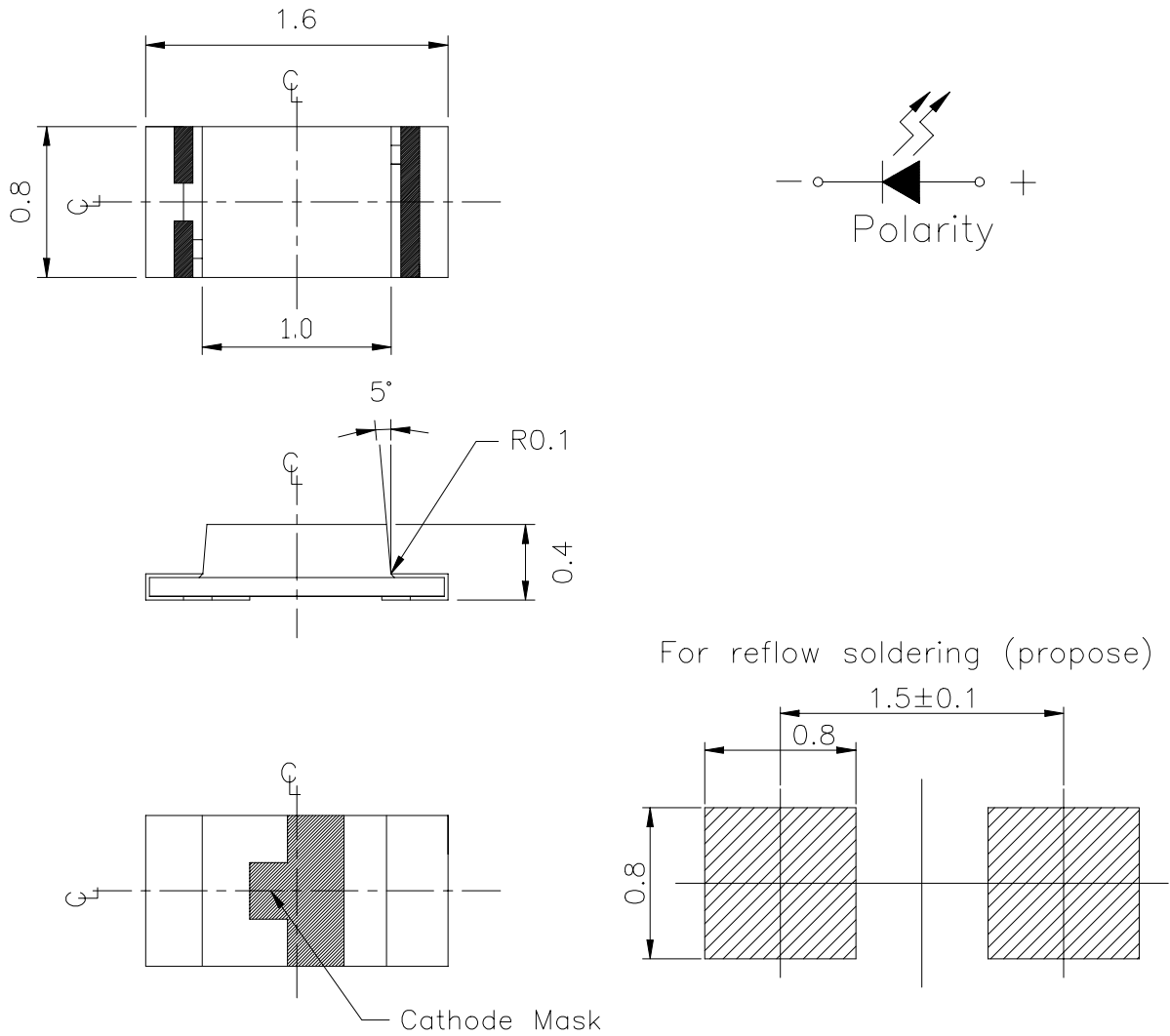

Note: The tolerances unless mentioned is $\pm 0.1\text{mm}$, Angle $\pm 0.5^\circ$,Unit = mm

Absolute Maximum Ratings (Ta=25°C)

Parameter	Symbol	Rating	Unit
Reverse Voltage	V _R	5	V
Forward Current	I _F	25	mA
Operating Temperature	T _{opr}	-40 ~ +85	°C
Storage Temperature	T _{stg}	-40 ~ +90	°C
Soldering Temperature	T _{sol}	260 (for 5 seconds)	°C
Electrostatic Discharge	ESD	2000	V
Power Dissipation	P _d	100	mW
Peak Forward Current (Duty 1/10 @ 1KHz)	I _F	60	mA

Electro-Optical Characteristics (Ta=25°C)

Parameter	Symbol	Min.	Typ.	Max.	Unit	Condition
Peak Wavelength	λ_p	----	591	----	nm	I _F =20mA
Dominant Wavelength	λ_d	----	589	----	nm	
Spectrum Radiation Bandwidth	$\Delta\lambda$	----	15	----	nm	
Viewing Angle	2θ 1/2	----	120	----	deg	
Forward Voltage	V _F	----	2.0	2.4	V	
Reverse Current	I _R	----	----	10	μA	V _R =5V

19-217/Y5C Series
19-217/Y5C Series Explain Of Luminous Intensity:
IF=20mA

Part No.	Parameter	Symbol	Typ.	Bin	Min.	Max.	Unit
19-217/Y5C-P1Q2	Luminous Intensity	Iv	75	P1	45.0	57.0	mcd
				P2	57.0	72.0	
				Q1	72.0	90.0	
				Q2	90.0	112	
19-217/Y5C-Q1R1	Luminous Intensity	Iv	100	Q1	72.0	90.0	mcd
				Q2	90.0	112	
				R1	112	140	
19-217/Y5C-Q2R2	Luminous Intensity	Iv	135	Q2	90.0	112	mcd
				R1	112	140	
				R2	140	180	

Note:

The luminous intensity data did not including $\pm 15\%$ testing tolerance.

Typical Electro-Optical Characteristics Curves

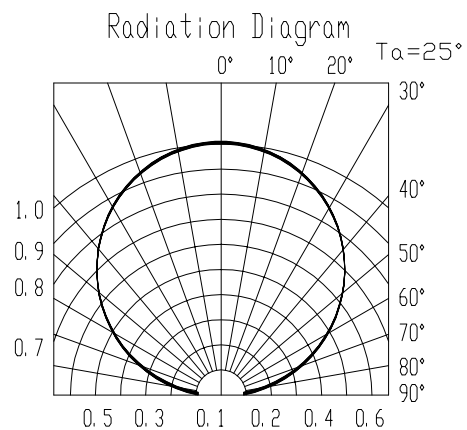
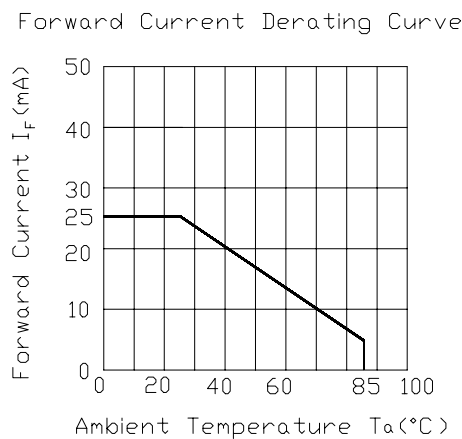
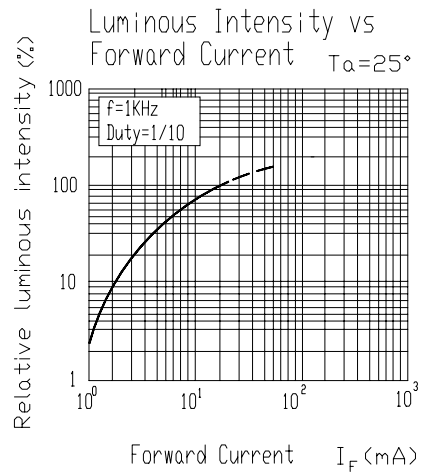
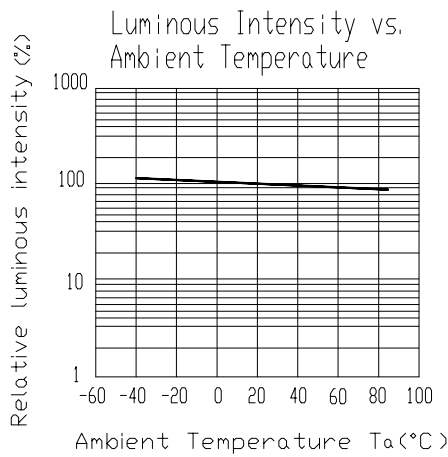
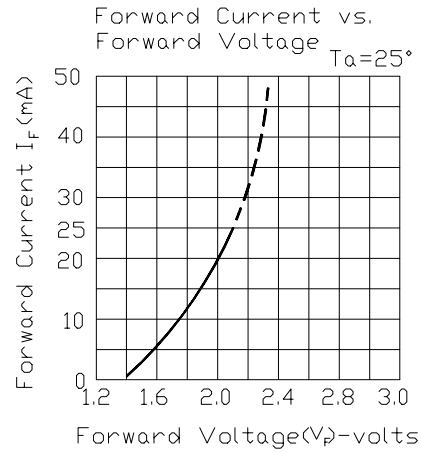
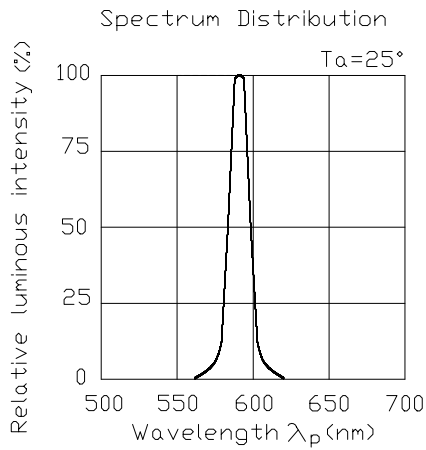

Label explanation

CAT: Luminous Intensity (mcd)

HUE: Dom. Wavelength (nm)

REF: Forward Voltage (V)



Reel Dimensions

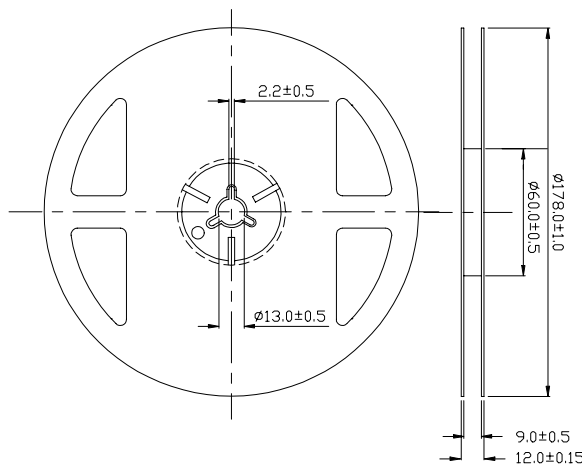

Taping Quantity: 3000pcs

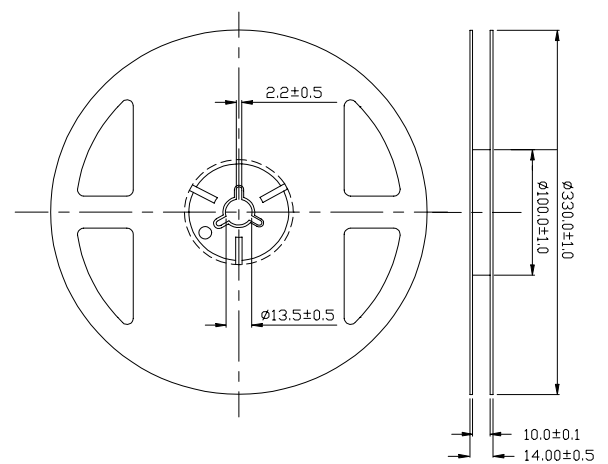

Taping Quantity: 5000pcs & 10000pcs

Note: The tolerances unless mentioned is $\pm 0.1\text{mm}$, Angle $\pm 0.5^\circ$,Unit = mm

Carrier Tape Dimensions

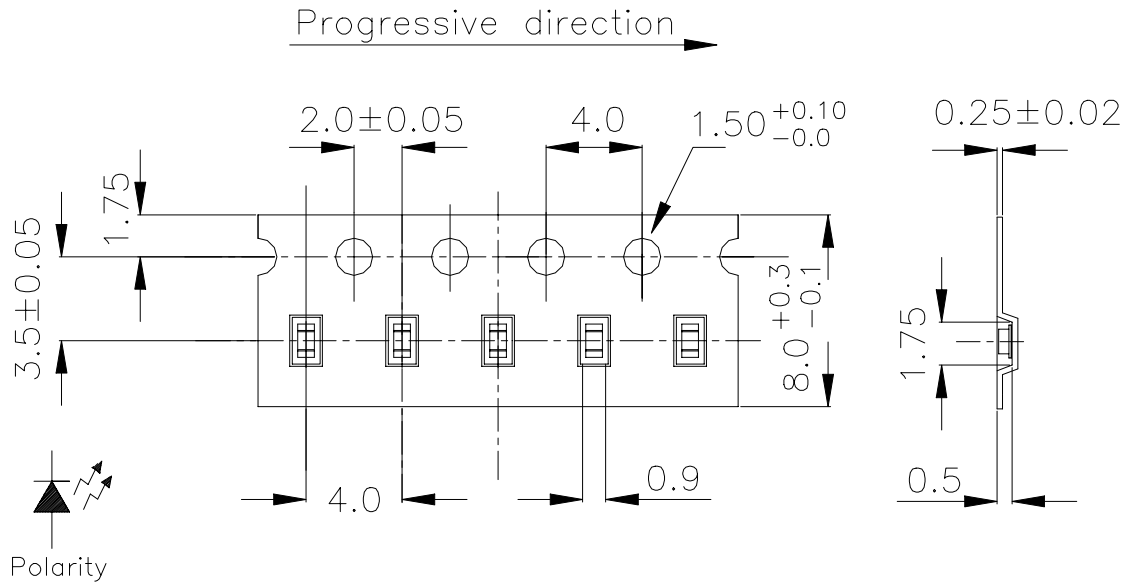

Note: The tolerances unless mentioned is $\pm 0.1\text{mm}$, Angle $\pm 0.5^\circ$,Unit = mm

Moisture Resistant Packaging

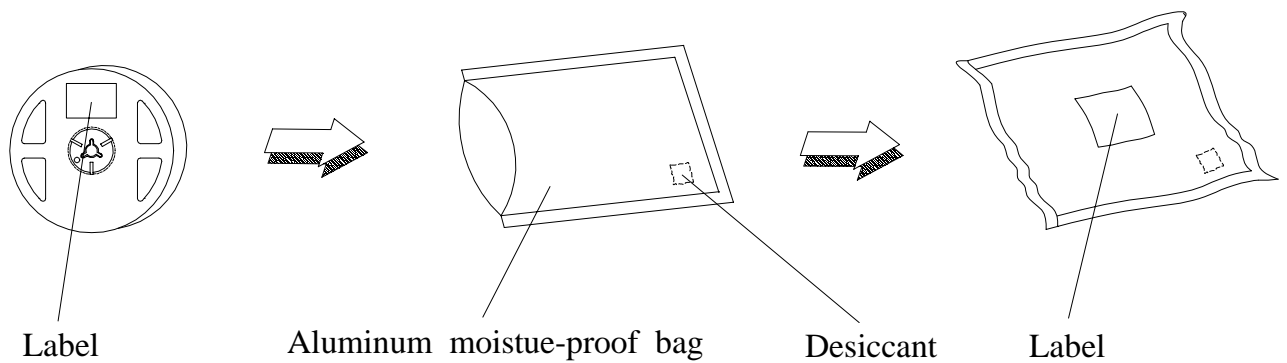

Reliability Test Items And Conditions

The reliability of products shall be satisfied with items listed below.

Confidence level : 90 %

LTPD : 10 %

No.	Items	Test Condition	Test Hours/Cycles	Sample Size	Ac/Re
1	Reflow	Temp. : 240°C ± 5°C Min. 5 sec.	6 min.	22 Pcs.	0/1
2	Temperature Cycle	H : +100°C 15min. ∫ 5 min. L : -40°C 15min.	300 Cycles	22 Pcs.	0/1
3	Thermal Shock	H : +100°C 5min. ∫ 10 sec. L : -10°C 5min.	300 Cycles	22 Pcs.	0/1
4	High Temperature Storage	Temp. : 100°C	1000 Hrs.	22 Pcs.	0/1
5	Low Temperature Storage	Temp. : -55°C	1000 Hrs.	22 Pcs.	0/1
6	DC Operating Life	IF = 20 mA	1000 Hrs.	22 Pcs.	0/1
7	High Temperature / High Humidity	85°C/R.H85%	1000 Hrs.	22 Pcs.	0/1

Precautions For Use

1. Over-current-proof

Customer must apply resistors for protection , otherwise slight voltage shift will cause big current change (Burn out will happen).

2. Storage time

2.1 The operation of Temperature and RH are : 5°C~35°C , RH60%.

2.2 Once the package is opened, the products should be used within a week.

Otherwise, they should be kept in a damp proof box with descanting agent.

Considering the tape life , we suggest our customers to use our products within a year(from production date).

2.3 If opened more than one week in an atmosphere 5°C~35°C , RH 60%, they should be treated at 60°C± 5°C for 15hrs.

2.4 When you discover that the desiccant in the package has a pink color (Normal = blue) , you should treat them in the same conditions as 2.3.

Soldering heat

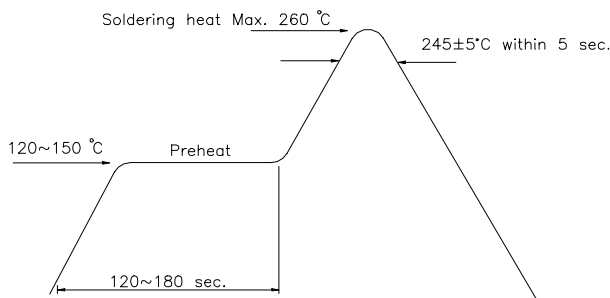

Reflow Temp / Time

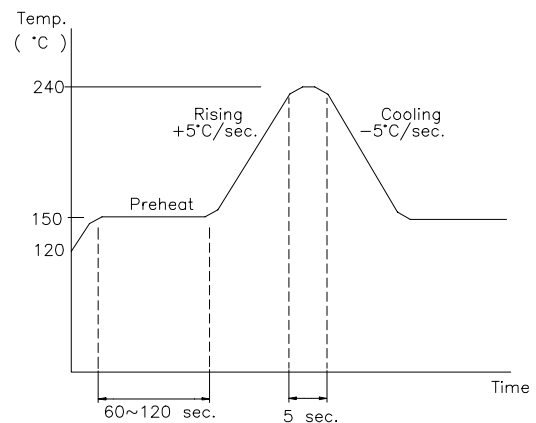

Soldering Iron

Basic spec is ≤ 5 sec when 260°C. If temperature is higher, time should be shorter (+10°C → -1sec). Power dissipation of Iron should be smaller than 15 W , and temperature should be controllable. Surface temperature of the device should be under 230 °C.

Rework

1. Customer must finish rework within 5 sec under 245°C.
2. The head of iron can not touch copper foil.
3. Twin-head type is preferred.

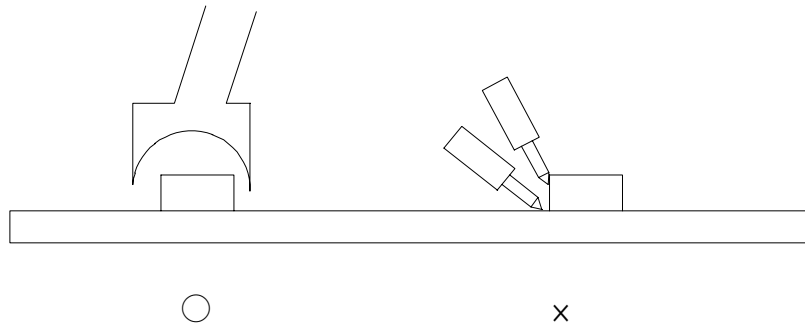
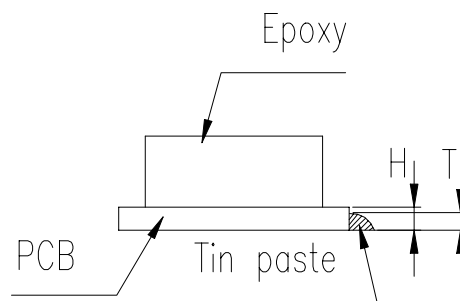
**Thickness of tin paste**

Thickness:
 $1/2H < T < H$

EVERLIGHT ELECTRONICS CO., LTD.
Office: No 25, Lane 76, Sec 3, Chung Yang Rd,
Tucheng, Taipei 236, Taiwan, R.O.C

Tel: 886-2-2267-2000, 2267-9936
Fax: 886-2267-6244, 2267-6189, 2267-6306
<http://www.everlight.com>